

FLEX

ELEKTROWERKZEUGE

LBE 76 12-EC

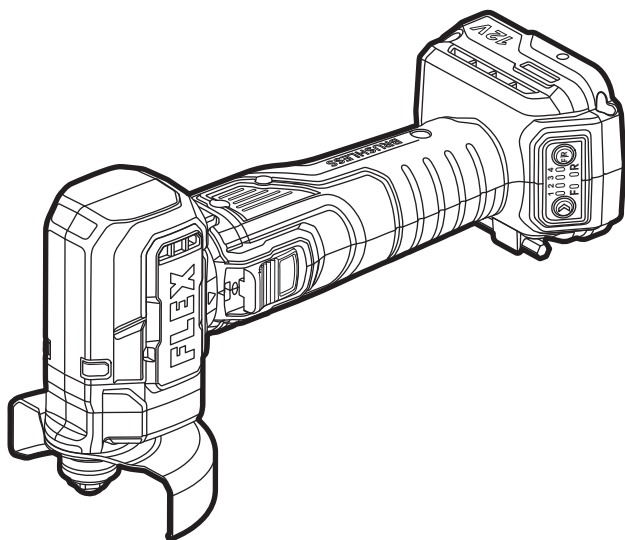

de	Originalbetriebsanleitung.....	10
en	Original operating instructions.....	25
fr	Notice d'instructions d'origine	37
it	Istruzioni per l'uso originali.....	51
es	Instrucciones de funcionamiento originales.....	65
pt	Instruções de serviço originais	79
nl	Originele gebruiksaanwijzing.....	93
da	Originale driftsvejledning	107
no	Originale driftsanvisningen.....	119
sv	Originalbruksanvisning	131
fi	Alkuperäinen käyttöohjekirja.....	143
el	Αυθεντικές οδηγίες χειρισμού.....	155
tr	Orijinal işletme kılavuzu.....	171
pl	Instrukcja oryginalna.....	183
hu	Eredeti üzemeltetési útmutató	197
cs	Originální návod k obsluze	210
sk	Originálny návod na obsluhu	222
hr	Originalna uputa za rad.....	234
sl	Izvirno navodilo za obratovanje	247
ro	Instrucțiuni de funcționare originale.....	259
bg	Оригинално упътване за експлоатация	273
ru	Оригинальная инструкция по эксплуатации	288
et	Originaalkasutusjuhend	303
lt	Originali naudojimo instrukcija	316
lv	Lietošanas pamācības oriģināls.....	329
ar	ترجمة لإرشادات التشغيل الأصلية.....	342

A

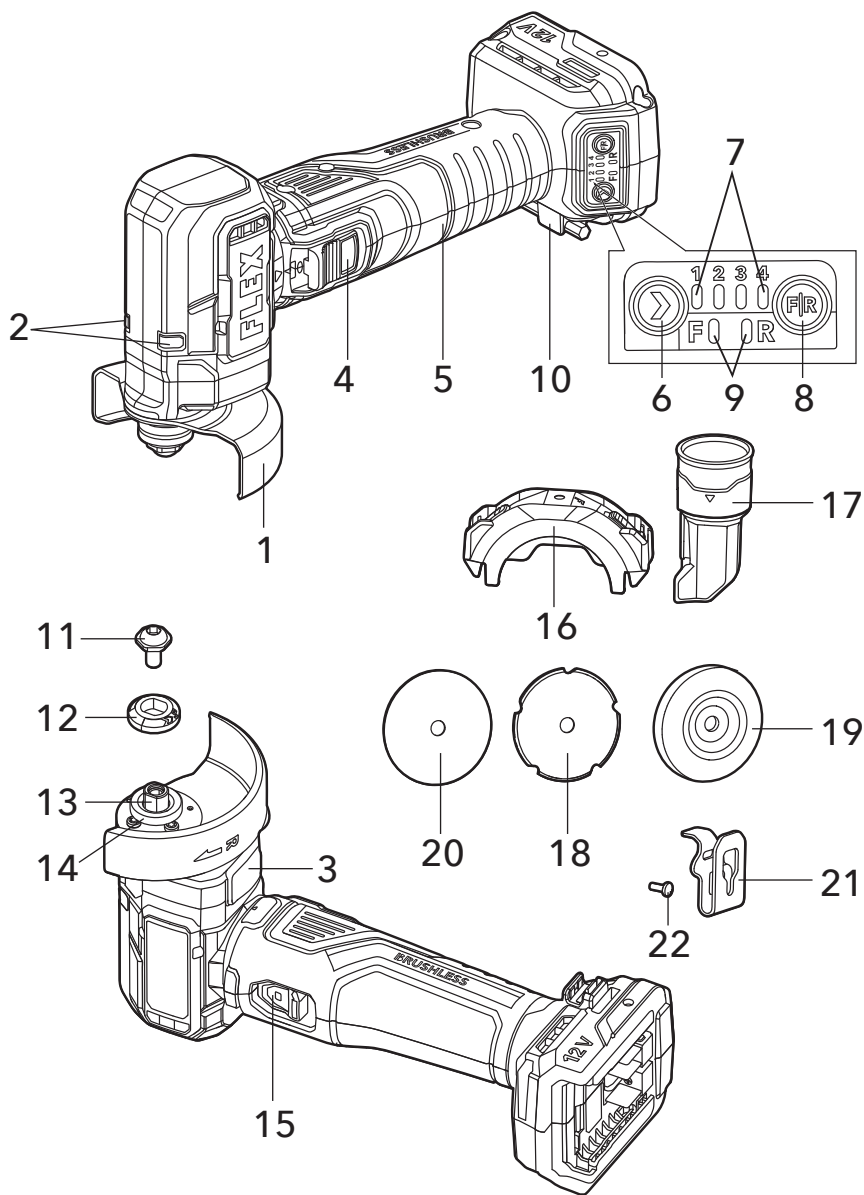

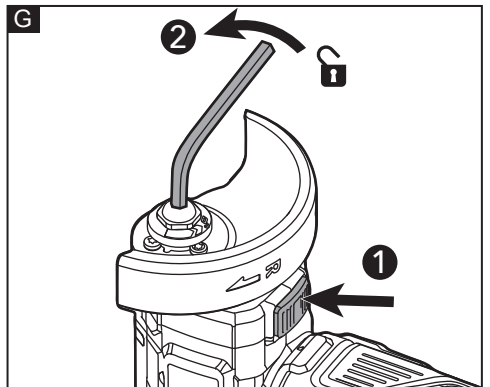
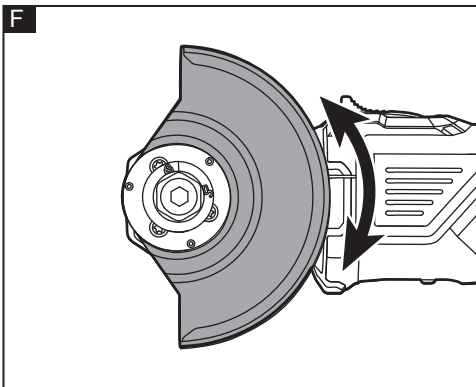
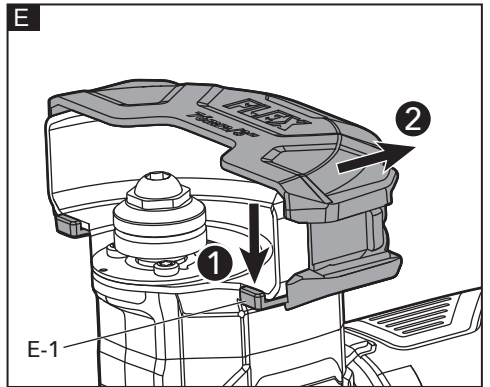
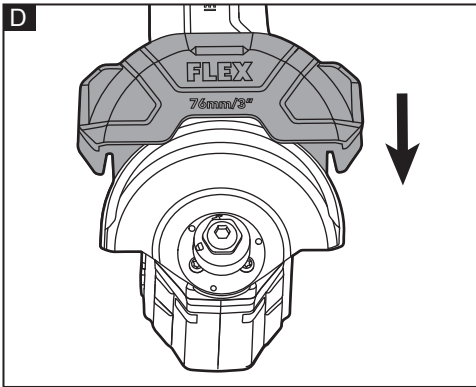
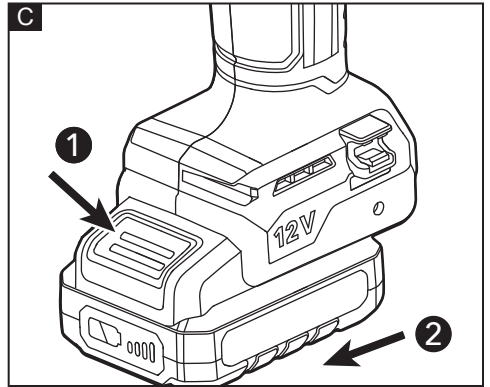
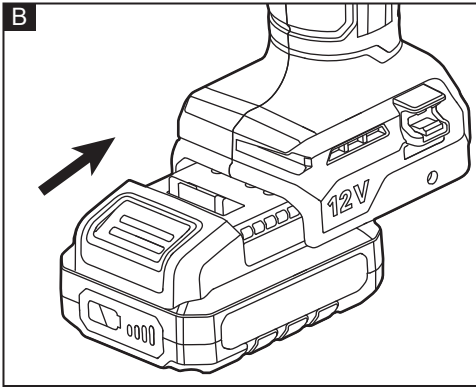

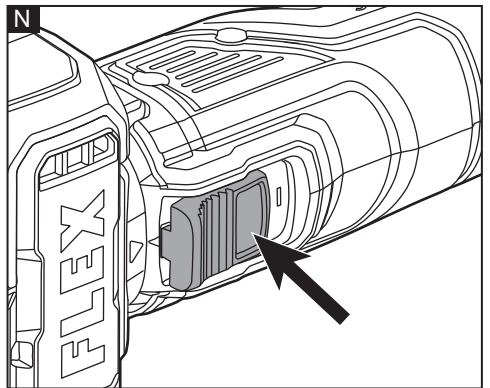
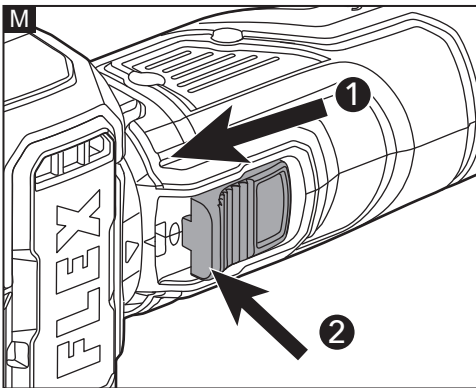
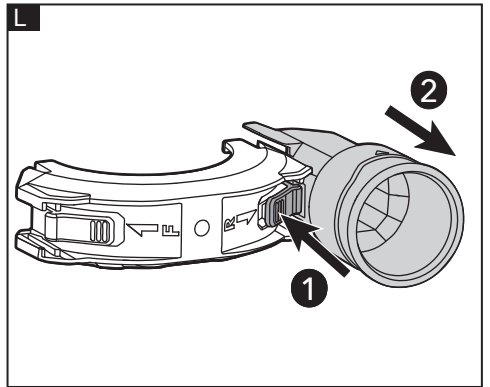
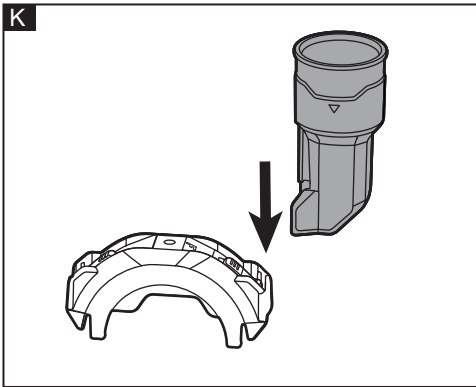
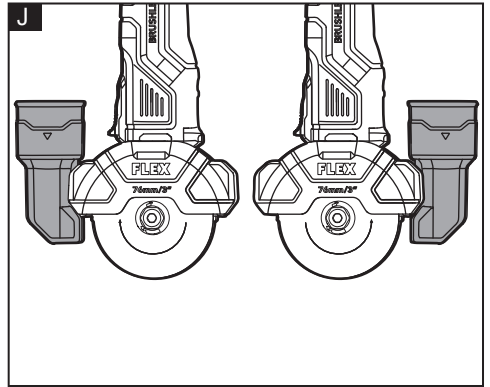
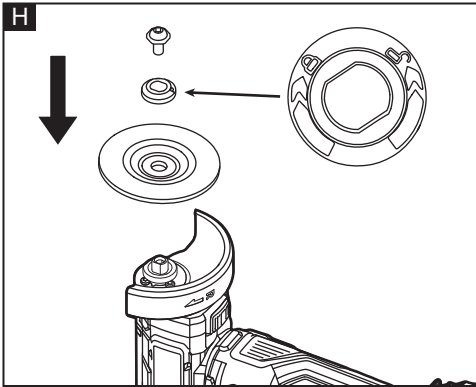

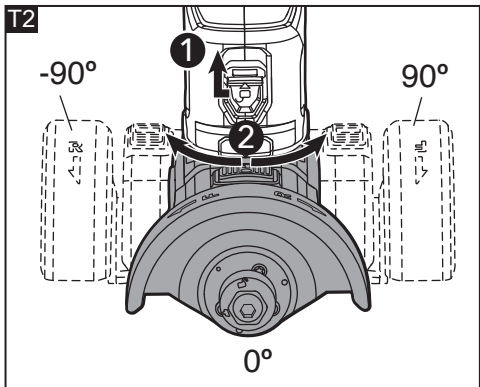
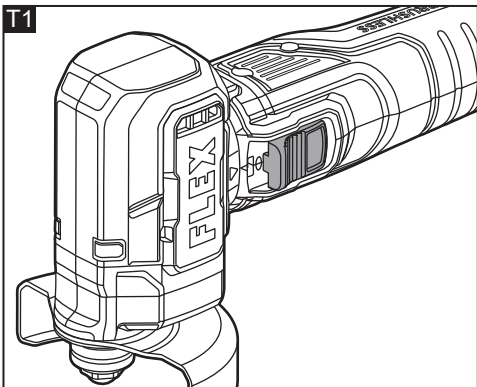
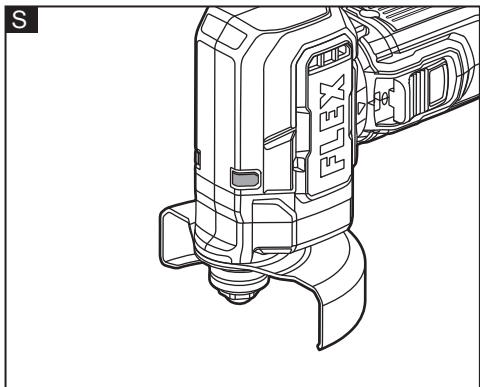
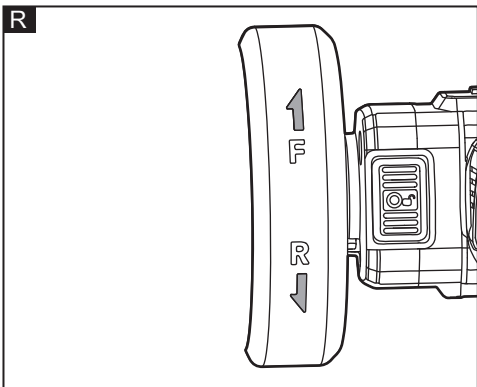
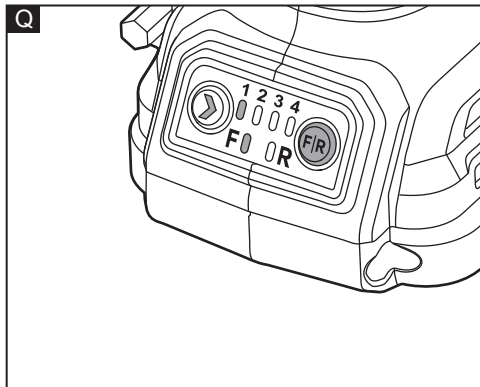
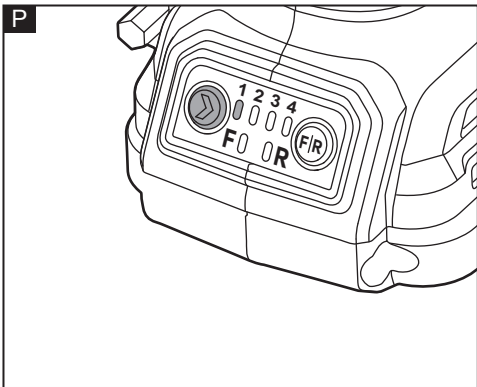



Symbols used in this manual



WARNING!

Denotes impending danger. Non-observance of this warning may result in death or extremely severe injuries.



CAUTION!





Denotes a possibly dangerous situation. Non-observance of this warning may result in slight injury or damage to property.



NOTE

Denotes application tips and important information.

Symbols on the power tool

V	Volts
/min	Revolutions or reciprocations per minute (rpm)
M	Metric thread
n_0	No load speed
D	Diameter
	Read the instructions
	Wear eye protection symbol
	Do not use the guard for cut-off operations
	Disposal information for the old machine (see page 16)!

For your safety



WARNING!

Before using the power tool, please read the follow:

- these operating instructions,
- the “General safety instructions” on the handling of power tools in the enclosed booklet (leaflet-no.: 315.915),
- the currently valid site rules and the regulations for the prevention of accidents.

This power tool is state of the art and has been constructed in accordance with the acknowledged safety regulations. Nevertheless, when in use, the power tool may be a danger to life and limb of the user or a third party, or the power tool or other property may be damaged.

The mini grinder may be used only

- as intended,
- in perfect working order.

Faults which impair safety must be repaired immediately.

Intended use

This grinder is intended for cutting and roughing of metal, concrete, stone, tiles, wood, plastics and similar materials without the use of water. The protection guard for cutting must be used when cutting.

Safety instructions for mini grinder

Safety instructions for all operations

Safety warnings common for grinding, sanding, or cutting-off operations:

- **This power tool is intended to function as a grinder, sanding or cut-off tool. Read all safety warnings, instructions, illustrations and specifications provided with this power tool.** Failure to follow all instructions listed below may result in electric shock, fire and/or serious injury.
- **Operations such as wire brushing, polishing, hole cutting are not to be performed with this power tool.** Operations for which the power tool was not designed may create a hazard and cause personal injury.
- **Do not convert this power tool to operate in a way which is not specifically designed and specified by the tool manufacturer.** Such a conversion may result in a loss of control and cause serious personal injury.
- **Do not use accessories which are not specifically designed and specified by the tool manufacturer.** Just because the accessory can be attached to your power tool, it does not assure safe operation.

- **The rated speed of the accessory must be at least equal to the maximum speed marked on the power tool.** Accessories running faster than their rated speed can break and fly apart.
 - **The outside diameter and the thickness of your accessory must be within the capacity rating of your power tool.** Incorrectly sized accessories cannot be adequately guarded or controlled.
 - **The dimensions of the accessory mounting must fit the dimensions of the mounting hardware of the power tool.** Accessories that do not match the mounting hardware of the power tool will run out of balance, vibrate excessively and may cause loss of control.
 - **Do not use a damaged accessory. Before each use inspect the accessory such as abrasive wheels for chips and cracks, backing pad for cracks, tear or excess wear, wire brush for loose or cracked wires. If power tool or accessory is dropped, inspect for damage or install an undamaged accessory. After inspecting and installing an accessory, position yourself and bystanders away from the plane of the rotating accessory and run the power tool at maximum no-load speed for one minute.** Damaged accessories will normally break apart during this test time.
 - **Wear personal protective equipment. Depending on application, use face shield, safety goggles or safety glasses. As appropriate, wear dust mask, hearing protectors, gloves and workshop apron capable of stopping small abrasive or workpiece fragments.** The eye protection must be capable of stopping flying debris generated by various applications. The dust mask or respirator must be capable of filtering particles generated by the particular application. Prolonged exposure to high intensity noise may cause hearing loss.
 - **Keep bystanders a safe distance away from work area. Anyone entering the work area must wear personal protective equipment.** Fragments of workpiece or of a broken accessory may fly away and cause injury beyond immediate area of operation.
 - **Hold the power tool by insulated gripping surfaces only, when performing an operation where the cutting accessory may contact hidden wiring or its own cord.** Cutting accessory contacting a “live” wire may make exposed metal parts of the power tool “live” and could give the operator an electric shock.
 - **Position the cord clear of the spinning accessory.** If you lose control, the cord may be cut or snagged and your hand or arm may be pulled into the spinning accessory.
 - **Never lay the power tool down until the accessory has come to a complete stop.** The spinning accessory may grab the surface and pull the power tool out of your control.
 - **Do not run the power tool while carrying it at your side.** Accidental contact with the spinning accessory could snag your clothing, pulling the accessory into your body.
 - **Regularly clean the power tool’s air vents.** The motor’s fan will draw the dust inside the housing and excessive accumulation of powdered metal may cause electrical hazards.
 - **Do not operate the power tool near flammable materials.** Sparks could ignite these materials.
 - **Do not use accessories that require liquid coolants.** Using water or other liquid coolants may result in electrocution or shock.
- Further safety instructions for all operations**
- KICKBACK AND RELATED WARNINGS:**
- Kickback is a sudden reaction to a pinched or snagged rotating wheel, backing pad, brush or any other accessory. Pinching or snagging causes rapid stalling of the rotating accessory which in turn causes the uncontrolled power tool to be forced in the direction opposite of the accessory’s rotation at the point of the binding.
- For example, if an abrasive wheel is snagged or pinched by the workpiece, the edge of the wheel that is entering into the pinch point can dig into the surface of the material causing the wheel to climb out or kick out. The wheel

may either jump toward or away from the operator, depending on direction of the wheel's movement at the point of pinching. Abrasive wheels may also break under these conditions.

Kickback is the result of power tool misuse and/or incorrect operating procedures or conditions and can be avoided by taking proper precautions as given below.

- **Maintain a firm grip on the power tool and position your body and arm to allow you to resist kickback forces. Always use auxiliary handle, if provided, for maximum control over kickback or torque reaction during start-up.** The operator can control torque reactions or kickback forces, if proper precautions are taken.
- **Never place your hand near the rotating accessory.** Accessory may kickback over your hand.
- **Do not position your body in the area where power tool will move if kickback occurs.** Kickback will propel the tool in direction opposite to the wheel's movement at the point of snagging.
- **Use special care when working corners, sharp edges etc. Avoid bouncing and snagging the accessory.** Corners, sharp edges or bouncing have a tendency to snag the rotating accessory and cause loss of control or kickback.
- **Do not attach a saw chain woodcarving blade, segmented diamond wheel with a peripheral gap greater than 10 mm or toothed saw blade.** Such blades create frequent kickback and loss of control.

Additional safety instructions for grinding and cutting-off operations

Safety warnings specific for grinding and cutting-off operations:

- **Use only wheel types that are specified for your power tool and the specific guard designed for the selected wheel.** Wheels for which the power tool was not designed cannot be adequately guarded and are unsafe.

- **The grinding surface of center depressed wheels must be mounted below the plane of the guard lip.** An improperly mounted wheel that projects through the plane of the guard lip cannot be adequately protected.
- **The guard must be securely attached to the power tool and positioned for maximum safety, so the least amount of wheel is exposed towards the operator.** The guard helps to protect the operator from broken wheel fragments, accidental contact with wheel and sparks that could ignite clothing.
- **Wheels must be used only for specified applications. For example: do not grind with the side of cut-off wheel.** Abrasive cut-off wheels are intended for peripheral grinding, side forces applied to these wheels may cause them to shatter.
- **Always use undamaged wheel flanges that are of correct size and shape for your selected wheel.** Proper wheel flanges support the wheel thus reducing the possibility of wheel breakage. Flanges for cut-off wheels may be different from grinding wheel flanges.
- **Do not use worn down wheels from larger power tools.** A wheel intended for larger power tool is not suitable for the higher speed of a smaller tool and may burst.
- **When using dual purpose wheels always use the correct guard for the application being performed.** Failure to use the correct guard may not provide the desired level of guarding, which could lead to serious injury.

Additional safety instructions for cutting-off operations

Additional safety warnings specific for cutting-off operations:

- **Do not "jam" the cut-off wheel or apply excessive pressure. Do not attempt to make an excessive depth of cut.** Overstressing the wheel increases the loading and susceptibility to twisting or binding of the wheel in the cut and the possibility of kickback or wheel breakage.

- **Do not position your body in line with and behind the rotating wheel.** When the wheel, at the point of operation, is moving away from your body, the possible kickback may propel the spinning wheel and the power tool directly at you.
- **When the wheel is binding or when interrupting a cut for any reason, switch off the power tool and hold it motionless until the wheel comes to a complete stop. Never attempt to remove the cut-off wheel from the cut while the wheel is in motion otherwise kickback may occur.** Investigate and take corrective action to eliminate the cause of wheel binding.
- **Do not restart the cutting operation in the workpiece. Let the wheel reach full speed and carefully re-enter the cut.** The wheel may bind, walk up or kickback if the power tool is restarted in the workpiece.
- **Support panels or any oversized workpiece to minimize the risk of wheel pinching and kickback.** Large workpieces tend to sag under their own weight. Supports must be placed under the workpiece near the line of cut and near the edge of the workpiece on both sides of the wheel.
- **Use extra caution when making a “pocket cut” into existing walls or other blind areas.** The protruding wheel may cut gas or water pipes, electrical wiring or objects that can cause kickback.
- **Do not attempt to do curved cutting.** Overstressing the wheel increases the loading and susceptibility to twisting or binding of the wheel in the cut and the possibility of kickback or wheel breakage, which can lead to serious injury.

Additional safety instructions for sanding operations

Safety warnings specific for sanding operations:

- ~~**Use proper sized sanding disc paper. Follow manufacturers recommendations, when selecting sanding paper. Larger sanding paper extending too far beyond the sanding pad presents a laceration hazard and may cause snagging, tearing of the disc or kickback.**~~

Noise and vibration

The noise and vibration values have been determined in accordance with EN 62841. The A evaluated noise level of the power tool is typically:

- Sound pressure level L_{pA} : xx dB(A);
 - Sound power level L_{WA} : xx dB(A);
 - Uncertainty: K = xx dB.
- Total vibration value:
- Emission value a_h : xx m/s^2
 - Uncertainty: K = xx m/s^2



CAUTION!

The indicated measurements refer to new power tools. Daily use causes the noise and vibration values to change.



NOTE

The declared vibration total value(s) and the declared noise emission level given in this information sheet has been measured in accordance with a measurement method standardized in EN 62841 and may be used to compare one tool with another.

It may be used for a preliminary assessment of exposure. The specified vibration emission level represents the main applications of the tool.

However, if the tool is used for different applications, with different cutting accessories or poorly maintained, the vibration emission level may differ.

This may significantly increase the exposure level over the total working period.

To make an accurate estimation of the vibration exposure level, it is also necessary to take into account the times when the tool is switched off or running but not actually in use.

This may significantly decrease the exposure level over the total working period.

Identify additional safety measures to protect the operator from the effects of vibration such as: maintain the tool and the cutting accessories, keep the hands warm, organization of work patterns.



WARNING:

The vibration and noise emissions during actual use of the power tool can differ from the declared value in which the tool is used; In order to protect the operator, user should wear gloves and ear protectors in the actual conditions of use.

**CAUTION!**

Wear ear defenders at a sound pressure above 85 dB(A).

**CAUTION!**

Grinding thin sheets of metal or other easily vibrating structures with a large surface can result in a total noise emission much higher (up to 15 dB) than the declared noise emission values. Such workpieces should as far as possible be prevented from emitting sound by suitable measures such as the application of heavy flexible damping mats. The increased noise emission is also to be considered for both the risk assessment of noise exposure and selecting adequate hearing protection.

Technical data

Tool		LBE 76 12-EC	
Type		Mini grinder	
Rated voltage	Vdc	12	
No-load speed	/min	20000	
Wheel type	Type 27 & Type 41		
Max. wheel diameter	mm	76	
Mounting hole diameter	mm	10	
Max. grinding wheel thickness	mm	4	
Max. cut-off wheel thickness	mm	4	
Weight according to "EPTA Procedure 01/2003" (without battery)	kg	0.8	
Battery	12V	AP 12/2.5 AP 12/4.0 AP 12/5.0	
Weight of battery	kg	AP 12/2.5	0.3
		AP 12/4.0	0.4
		AP 12/5.0	0.4
Working temperature	-10~40°C		



Storage temperature	< 50°C
Charging temperature	4~40°C
Charger	CA 12/18, CA 12

**NOTE**

The battery pack and charger manuals are provided separately. They include specific safety rules and operating instructions. Please refer to the battery pack and charger manuals for safety rules and detailed operating instructions.

Overview (see figure A)

The numbering of the product features refers to the illustration of the machine on the graphics page.

1. **Protection guard for grinding**
2. **LED work light**
3. **Spindle lock button**
4. **On/off switch**
5. **Handle**
6. **Speed-selection button**
7. **Speed indicator**
8. **Direction-of-Rotation selector**
9. **Direction-of-Rotation indicator**
10. **Hex key & storage**
11. **Bolt** 
12. **Outer flange**
13. **Spindle**
14. **Inner flange**
15. **Rotation release button**
16. **Protection guard for cutting**
17. **Dust Port**
18. **Carbide abrasive cut-off wheel**
19. **Grinding wheel**
20. **Metal cut-off wheel (2)** 
21. **Removable belt clip**
22. **Fastening screw**



Operating instructions

 **WARNING!**
Remove the battery before carrying out any work on the power tool.

Before switching on the power tool

Unpack the cordless mini grinder and check that there are no missing or damaged parts.

 **NOTE**
The batteries are not fully charged on delivery. Prior to initial operation, charge the batteries fully. Refer to the charger operating manual.

Inserting/replacing the battery

- Press the charged battery into the power tool until it clicks into place (see figure B).
- To remove, press the release button and pull out the battery (see figure C).

 **CAUTION!**
When the device is not in use, protect the battery contacts. Loose metal parts may short circuit the contacts, explosion and fire hazard!

Protection guard

 **WARNING!**
Only use the tool if the protection guard is in place. Always use the protection guard provided for the respective wheel!

 **WARNING!**
Turn the protection guard until the closed section is facing the operator.

Protection guard for grinding (1)

Designed for work with grinding wheels and flap discs.

 **WARNING!**
When use this guard for cutting-off operations with bonded abrasive wheels, there is an increased risk of exposure to emitted sparks and particles, as well as exposure to wheel fragments in the event of wheel burst.

 **WARNING!**
When use this guard for cutting-off and facial operations in concrete or masonry, there is an increased risk of exposure to dust and loss of control resulting in kickback.

Protection guard for cutting (16)

Designed for work with cutting-off wheels.

 **WARNING!**
Always attach the protection-guard for cutting (16) when performing cutting work. Before use, check for cracks, deformations or signs of severe wear and tear.

 **WARNING!**
When use this cut-off guard for facial grinding, the wheel guard may interfere with the workpiece causing poor control.

Fitting (see figure D)

Push the protection guard for cutting (16) onto the protection guard for grinding (1), until it engages. 

Removal (see figure E)

Bend one of the two latching hooks (E-1) a bit carefully until the latching hook does not protrude anymore from the guard rim. Then pull off the protection guard for cutting and put aside.

Adjusting the protection guard (see figure F)

Turn the protection guard to the desired position until it engages. No tool is required for this.



Cut-off wheel selection

Selecting the correct type of wheel is important in order to obtain the best performance from the saw. Select the wheel based on the application and on the material you wish to cut. Selecting the right wheel will give you a smoother, faster cut and prolong the life of the wheel.

Even the best cut-off wheels will not cut efficiently if they are not kept clean and sharp. Using a dull wheel will place a heavy load on the saw and increase the danger of kickback. Keep extra wheels on hand so that sharp wheels are always available.

Always carefully select and use cut-off wheels that are recommended for the material being cut. Make sure that the minimum operating speed of any accessory wheel selected is 20,000 /min (RPM) or more.

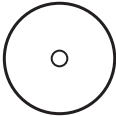
Refer to the table below to select a suitable cut-off wheel and set recommended direction of rotation.

CUT-OFF WHEEL		APPLICATIONS
	Carbide abrasive cut-off wheel i NOTE if diamond segmented, maximum peripheral gap between segments is 10 mm, only with a negative rake angle.	Cutting drywall, plastic. The arrow on the wheel indicates the ONLY direction the wheel should rotate when the tool is in use. Always make sure the direction of rotation selector is in the position that matches the direction of rotation marked on the wheel.
	Metal cut-off wheel	Cutting steel, stainless steel, non-ferrous materials.
	Diamond tile cut-off wheel (not supplied)	Cutting tile, ceramics, fiber cement. Recommended direction of rotation: The arrow on the wheel indicates the ONLY direction the wheel should rotate when the tool is in use. Always make sure the direction of rotation selector is in the position that matches the direction of rotation marked on the wheel.

Attaching and removing the wheel

WARNING!

When working with cutting-off wheels, fit the protection ~~guard~~ for cutting (16).

To install the wheel (see figure G & H)

- Remove the battery
- Clean the spindle and all parts to be mounted.
- Press and hold down the spindle lock button (3)
- Using the hex key (10), loosen the bolt (11) on the spindle (13) counterclockwise and remove the bolt (11) and outer flange (12).
- Place the wheel on the inner flange.

i **NOTE**

When installing grinding wheel, the protruded section of the wheel must face to the inner flange.

- Reinstall the outer flange (12) with the printing surface is facing outwards.
- Press and hold down the spindle lock (3).

- Tighten the bolt (11) with the hex key clockwise. The recommended torque is 5Nm.
- Insert the battery.
- Switch on the grinder (without locking into position) and leave the grinder running for approx.30 seconds. Check for imbalances and vibrations.
- Switch off the grinder and remove the battery.

To remove the wheel

- Press and hold down the spindle lock button (3)
- Loosen the bolt using the hex key and remove the bolt and outer flange from the spindle.
- Remove the wheel.

Dust port

i **NOTE**

The dust port is only for tile/concrete and drywall cutting applications to connect to a vacuum for dust collecting. We do not recommend use of the dust port for metal cutting applications.

- Select the dust port installation position according to the rotation direction of cutting wheel (see figure J).
- Insert the dust port (17) to either end of the protection guard for cutting (16) until it engages (see figure K).
- Mount the protection guard for cutting (16) to the protection guard for grinding (1), refer to chapter "Protection guard".
- To remove the dust port: press the latch of the protection guard for cutting (16) and pull out the dust port (17) (see figure L).

Switching on and off (see figure M & N)

- To start the power tool, slide the on/off switch (4) forwards (step 1). For continuous operation, tilt it downwards until it engages (step 2).
- To switch off the power tool, press the rear end of the on/off switch and release it.

NOTE

After removing the battery, the switched on power tool does not restart.





Speed preselection (see figure P)

WARNING!

It is not recommended to adjust the speed when the spindle is rotating.

Your tool is equipped with a memory function. After turning the tool off, the tool will revert to the previous setting the next time it is turned on.

Press the speed-selection button (6) to cycle through four modes. Each press changes the speed by one level. The table below shows the relationship between rotational speed and the number of LEDs that shine on the foot of the tool.

The Number of LEDs	Speed (RPM)
 ON OFF	
	5000
	10000
	15000
	20000

Direction-of-rotation selector (see figure Q & R)

The tool is equipped with a direction-of-rotation selector. Some applications or accessories may require the tool to be run in forward or reverse.

For cut-off grinding, select the direction of cut that allows the tool to be pushed away from your body. When installing carbide abrasive cut-off wheel or diamond wheel, select the rotation direction that matches the arrow on the wheel.

1. Attach the battery.
2. Press the direction-of-rotation selector (8) to select the direction. Every time you press the selector, the direction of rotation will be switched. The direction-of-rotation indicator (9) will illuminate to indicate the active direction of rotation. If you choose "F", the cut-off wheel will rotate counter-clockwise in the direction of wheel rotation "F" marked on the guard. If you choose "R", the cut-off wheel will rotate clockwise in the direction of wheel rotation "R" marked on the guard.

NOTE

The direction-of-rotation indicator will turn off approximately 10 seconds after the direction-of-rotation selector is released, and it will revert to the previous setting when the tool is turned on again.

For cut-off grinding, the wheels provided with this tool have arrows indicating the direction the wheels should rotate when the tool is in use. Before operating the tool, make sure the direction-of-rotation selector is in the position that matches the direction of rotation marked on the wheel. Wheels without arrows can be operated in either forward or reverse.

WARNING!

For grinding with grinding wheel or flap wheel disc, it is mandatory only to use the standard ("F") direction in order to avoid damage on tools, which are not suitable for reverse directional use.

**WARNING!**

To prevent damage, always allow the wheel to come to a complete stop before changing the direction of rotation.

LED work light (see figure S)

The LED work light, located in the head of the tool, will illuminate when the tool is switched on or the speed-selection button (6) /direction-of-rotation selector (8) is depressed and will turn off approximately 10 seconds after the tool is switched off.

The LED work light (2) will rapidly flash when the tool and/or battery pack becomes overloaded or too hot, and the internal sensors will turn the tool off. Rest the tool for a while or place the tool and battery separately under air flow to cool them.

The LED work light (2) will flash more slowly to indicate that the battery is at low-battery capacity. Recharge the battery.

If the LED work light (2) fails to light up when you switch on the tool, or it turns off suddenly during your operation, it may be caused by the internal communication error. Please contact customer service or an authorized service center for assistance.

Adjusting the angle of tool head (see figure T1 & T2)

The tool head can be adjusted to 3 different working positions, 0°, -90° and 90°.

- Ensure the on/off switch is in OFF position.
- Remove the battery.
- While pulling down the rotation release button (15) all the way, rotate the tool head and release the button.
- Continue to rotate the tool head until it locks in place with a "click".

Operation Instructions**NOTE**

When the tool is switched off, the grinder continues running briefly.

Rough-grinding**WARNING!**

Never use cutting-off wheels for rough-grinding.

- Angle of wheel 20-40° for best cutting performance.

- Applying moderate pressure, move the tool backwards and forwards. As a result, the workpiece will not become too hot and there will be no discoloration; nor will there be any grooves.

Cut-off grinding**WARNING!**

For cutting with cut-off wheels, always use the protection-guard for cutting (16).

- Always work against the run of the wheel. Otherwise the tool may kick back from the cut in an out of control manner.
- Guide the tool evenly at a speed suitable for the material being processed.
- Do not tilt, apply excessive force or sway from side to side.

For further information on the manufacturer's products go to www.flex-tools.com.

Sanding

Press down the tool evenly on the surface and move back and forth so that the surface of the workpiece does not become too hot.

Maintenance and care**WARNING!**

Remove the battery before carrying out any work on the power tool.

Cleaning

- Clean the power tool and grille in front of the vent slots regularly. Frequency of cleaning is dependent on the material and duration of use.
- Regularly blow out the housing interior and motor with dry compressed air.

**Spare parts and accessories**

For other accessories, in particular tools and polishing-aids, see the manufacturer's catalogues.

Exploded drawings and spare-part lists can be found on our homepage:

www.flex-tools.com

Disposal information**WARNING!**

- Render redundant power tools unusable:
 - battery operated power tool by removing the battery.



EU countries only
Do not throw electric power tools into the household waste!

In accordance with the European Directive 2012/19/EU on Waste Electrical and Electronic Equipment and transposition into national law used electric power tools must be collected separately and recycled in an environmentally friendly manner.



Raw material recovery instead of waste disposal.

Device, accessories and packaging should be recycled in an environmentally friendly manner. Plastic parts are identified for recycling according to material type.



WARNING!

Do not throw batteries into the household waste, fire or water. Do not open used batteries.

EU countries only:
In accordance with Directive 2006/66/EC defective or used batteries must be recycled.



NOTE

Please ask your dealer about disposal options!

CE Declaration of conformity

We declare on our sole responsibility that the product described in "Technical specifications" conforms to the following standards or normative documents:

EN 62841 in accordance with the regulations of the directives 2014/30/EU, 2006/42/EC, 2011/65/EU.

Responsible for technical documents:
FLEX-Elektrowerkzeuge GmbH, R & D
Bahnhofstrasse 15, D-71711 Steinheim/Murr

i.v. Peter Lameli 

Peter Lameli
Technical Head

Klaus Peter Weinper
Head of Quality
Department (QD)

1.12.2023; FLEX-Elektrowerkzeuge GmbH
Bahnhofstrasse 15, D-71711 Steinheim/Murr

Exemption from liability

The manufacturer and his representative are not liable for any damage and lost profit due to interruption in business caused by the product or by an unusable product.

The manufacturer and his representative are not liable for any damage which was caused by improper use of the product or by use of the product with products from other manufacturers.

UK CA Declaration of Conformity

We as the manufacturer: **FLEX Elektrowerkzeuge GmbH**, Business address: **Bahnhofstr. 15, 71711 Steinheim, Germany** declare under our sole responsibility, that the product(s) described under „Technical specifications“ fulfills all the relevant provisions of **The Supply of Machinery (Safety) Regulations S.I. 2008/1597** and also fulfills all the relevant provisions of the following UK Regulations:

Electromagnetic Compatibility Regulations S.I. 2016/1091, The Restriction of the Use of Certain Hazardous Substances in Electrical and Electronic Equipment Regulations S.I. 2012/3032 and are manufactured in accordance with the following designated Standards:

BS EN IEC 62841-1

BS EN IEC 62841-2-3

BS EN IEC 55014-1

BS EN IEC 55014-2



Place of declaration: **Steinheim, Germany.**
Responsible person: **Peter Lameli, Technical Director - FLEX-Elektrowerkzeuge GmbH**
Contact details for Great Britain: FLEX Power Tools Limited, Unit 8 Anglo Office Park, Lincoln Road, HP 12, 3RH Buckinghamshire, United Kingdom.

i.v. Peter Lameli 

Peter Lameli
Technical Head

Klaus Peter Weinper
Head of Quality
Department (QD)

1.12.2023

Flex-Elektrowerkzeuge GmbH
Bahnhofstr. 15 71711 Steinheim/Murr
Tel. +49(0) 7144 828-0
Fax +49(0) 7144 25899
info@flex-tools.com
www.flex-tools.com
